



GS SHEAR

The Harris GS Baler/Logger/Shear was designed to deliver a new generation of performance that will keep pace with a company's sustained growth and provide an overall lower operating cost per ton. The baling chamber and resulting bale size are engineered to meet mill specifications of electric arc furnace (EAF) operators.

The Harris GS series offers superiority by utilizing 100HP motors, horizontal mounted pumps, and an independent load table, which allows for more visual inspection of material by the operator when the load is dumped into the charging box. Harris incorporates a simple to use OIT (operator interface terminal) control panel with basic commands, operational information and diagnostics. Production reporting is also included.

Harris has always utilized "regenerative circuits" on large cylinder flows. Harris also has a TRUE clamshell box for superior trapping and sizing of bulky material. Harris is manufactured in the US using US components and tested at the factory prior to shipment. Service and parts supported by Harris' well trained staff of service technicians and support personnel.

FEATURES:

- Through bolt, leaf type individual hinges are very durable and easy to service.
- GS 9 is prewired for easier installation.
- Grease lubrication system.
- Shear and clamp cylinders are easily accessible from the top of the shear frame.

SHEARING:

Miscellaneous scrap, select #1 and #2 scrap, shapes, plate, pipe.

BALING/LOGGING:

Miscellaneous scrap, white goods, auto fenders, etc, factory clips & skeletons.



800.373.9131

770.631.7290

www.harrisequip.com





External gib and blade adjustment, no shimming is required.

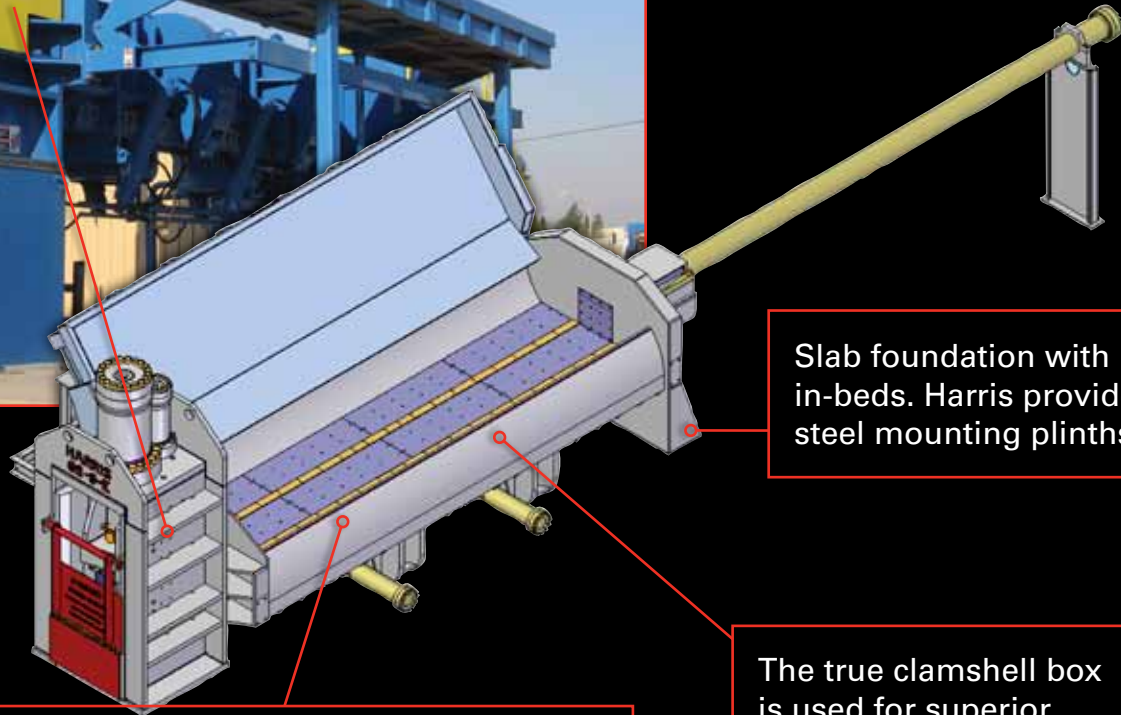

Slab foundation with in-beds. Harris provides steel mounting plinths.

The true clamshell box is used for superior trapping and sizing of bulky material.

Superior cylinder mount geometry allows for greater mechanical advantage resulting in higher side compression forces on material.



Replaceable liner plates, shear frame and charge box. All lined surfaces are machined for a precision fit.

Flame hardened cylinder rods are utilized with heavy wall thickness on cylinder tubes along with TFE piston seals.

Shear blades are through bolted – if properly torqued; bolt tightness is not an issue.

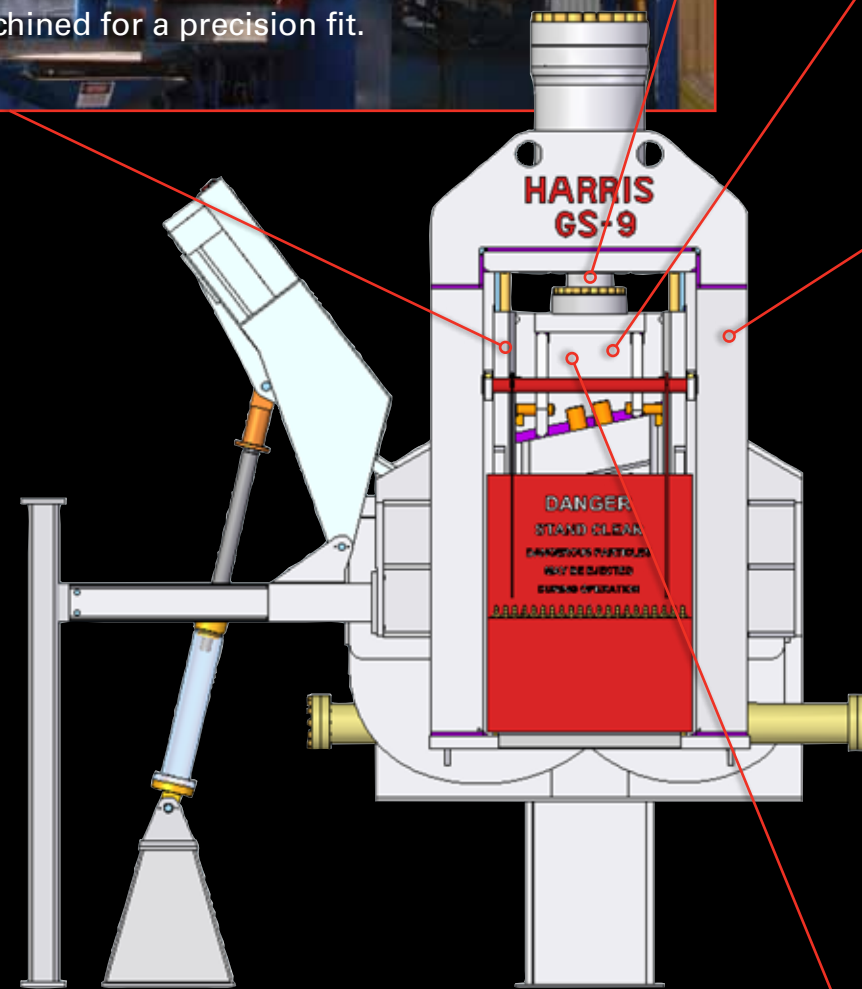

Heavy Duty frame construction with weight considerably heavier than competition.

12 degree cutting angle shear knife for improved shearing efficiency.